

CNC-Machines

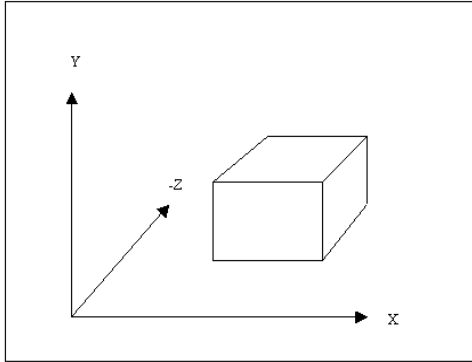

Tronrud Engineering has several CNC-machines for different kind of production. In this document you will find a full list of all our machines.

Do not hesitate to contact us if you have any questions.

Contact:
 Nils Elsrud, Sales Manager
 Mob: +47 915 66 980
 Mail: nils.elsrud@tronrud.no

Deckel DMU 50



Class of Machinery	Mill Vertical w/2 axis roundtable
Axis	3 + 2 rot (B/C) aut. index.
X in mm	500
Y in mm	400
Z in mm	400
Tools	30

ECO Mill 1100 V



Class of Machinery	Mill Vertikal
Axis	4
X in mm	1100
Y in mm	960
Z in mm	500
Tools	32

ECO Mill 50 x 2 machines

	Class of Machinery	Mill Vertikal
	Axis	5
	X in mm	500
	Y in mm	400
	Z in mm	400
	Tools	32

Gildemeister NEF520

	Class of Machinery	Turn
	Axis	2 + spindle og revolving tool
	Max dia.	Ø265 mm
	Max Length	1400 mm
	Tools	8

HAAS EC300

	Class of Machinery	Mill Horizontal w/2 pal. Indexert 4.-akse
	Axis	3 + 1 (B) 4.-axis aut. index.
	X in mm	508
	Y in mm	450
	Z in mm	350
	Tools	24

Haas VF11

	Class of Machinery	Mill Vertical w/X-axis in table
	Axis	3
	X in mm	3016
	Y in mm	1016
	Z in mm	800
	Tools	24

Haas VF2 x 2 machines

	Class of Machinery	Mill Vertical w/X-axis in table3
	Axis	3
	X in mm	700
	Y in mm	400
	Z in mm	500
	Tools	24

Haas VF4SS

	Class of Machinery	Mill Vertikal
	Axis	3
	X in mm	1270
	Y in mm	509
	Z in mm	620
	Tools	24

Kimtech Water Jet

	Class of Machinery	Water Jet Cutting Vertikal
	X in mm	3000
	Y in mm	2000
	Z in mm	180

Mori Seiki NH4000 DCG

	Class of Machinery	Mill Horizontal w/2 pal.
	Axis	3 + 1 (B) 4.-axis simultaneous.
	X in mm	560
	Y in mm	560
	Z in mm	700
	Tools	60

Mori Seiki NMV5000 DCG

	Class of Machinery	Mill Vertical
	Axis	5 Simultaneous
	X in mm	730
	Y in mm	510
	Z in mm	510
	Tools	60

Mori Seiki NVX5100

	Class of Machinery	Mill Vertical w/X-axis in table
	Axis	3
	X in mm	1050
	Y in mm	500
	Z in mm	510
	Tools	30

Mori Seki NL2000 x 2 machines

	Class of Machinery	Turn/Mill w/ rot. tool
	Axis	2 + C/Y + Sub
	Max dia.	Ø270 mm
	Max Length	510 mm
	Tools	10

Mori Seki NL2500

	Class of Machinery	Turn/Mill w/ rot. tool
	Axis	2+C
	Max dia.	Ø 356 mm
	Max Length	700 mm
	Tools	10

Rambaudi SARA

	Class of Machinery	Mill Vertikal
	Axis	3
	X in mm	3200
	Y in mm	2400
	Z in mm	900
	Tools	30

Unisign Univers 5

	Class of Machinery	Mill Vertikal w/firm table
	Axis	3
	X in mm	3950
	Y in mm	680
	Z in mm	400
	Tools	51

Deckel FP42nc



Class of Machinery	Mill Vertical w/firm table
Axis	3
X in mm	1200
Y in mm	500
Z in mm	300
Tools	Manuel

Deckel FP3nc



Class of Machinery	Mill Vertical w/X-axis in table
Axis	3
X in mm	400
Y in mm	400
Z in mm	300
Tools	Manuel